

soluble α -Klotho ELISA

Soluble α -Klotho has been widely studied in aging related disease research such as **Chronic Kidney Disease (CKD), Osteoporosis, Cardiovascular Disease and Alzheimer's Disease**. IBL's Human soluble α -Klotho detects **both full length (KL1+KL2) and KL1** is the mostly published and used by researchers

Best Selling

- #27998 Human soluble α -Klotho
- #27601 Mouse soluble α -Klotho

Customer Feedback (USA)

*"This assay doesn't need any additional feedback, because most of published human α -Klotho data referred on it. It is an absolutely wonderful assay and **the best** in the market."*

National Institute of Health (NIH)

α -Klotho – Transmembrane (TM) protein / mainly expressed in kidneys and parathyroid glands.

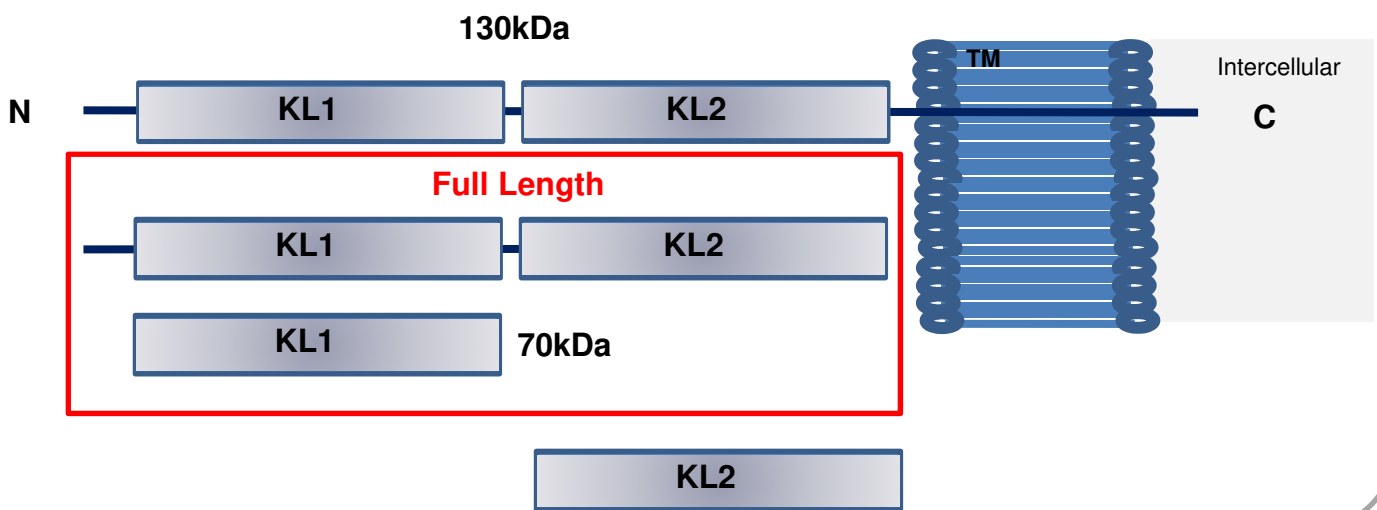

Negative Correlation (α -Klotho vs FGF23) In CKD (Chronic Kidney Disease) Stage

Human EDTA-Plasma

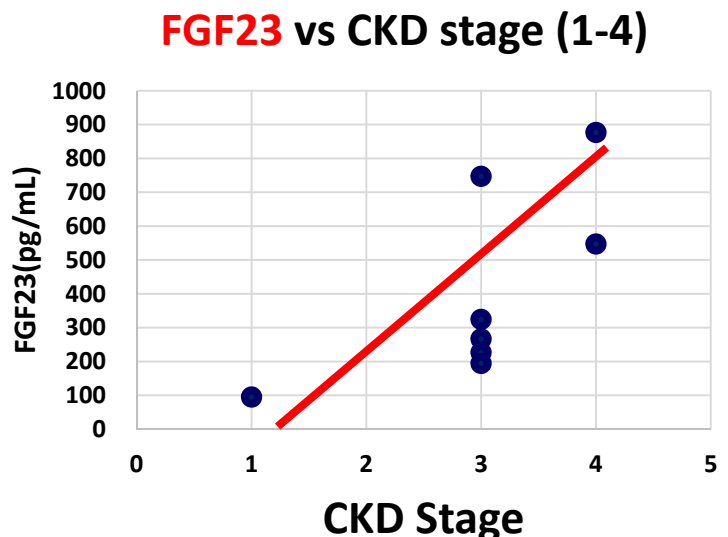
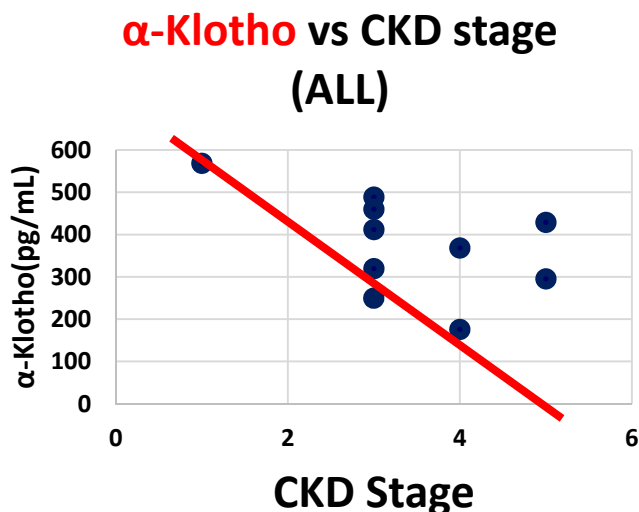

Data provided by Dr. Yuji Muraba, Cardiology, Hidaka Hospital

Measured level of each type of sample

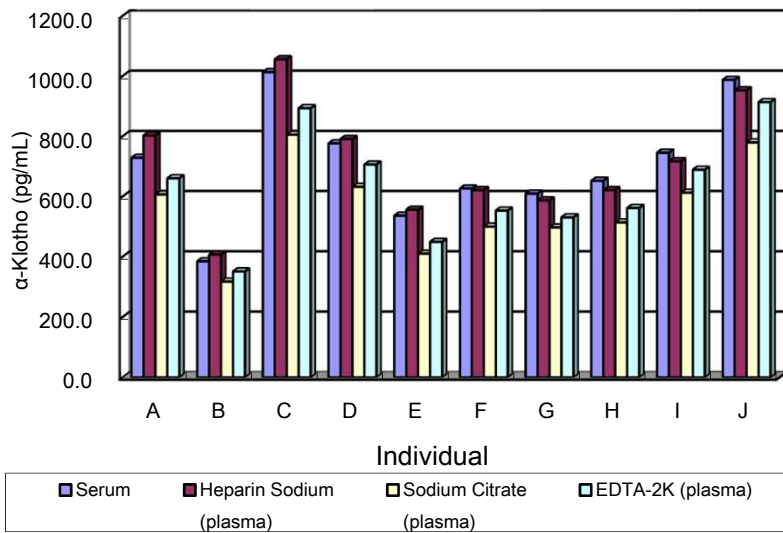

Package Size

96 Well ELISA

Sample

Serum, Plasma (EDTA, Heparin, Citrate),
Urine

Measurement Range

93.75 – 6,000 pg/mL

Sensitivity

6.15pg/mL

Assay Time

1hr (R.T.) + 30min (R.T.) + 30min (R.T.) = 2hr

Sample Stability

Frozen/Thaw test

Each sample was measured after frozen/thaw cycles, and the ratio (%) of measured value against the initial condition is shown in Table 1. Initial condition means samples right after thaw from previously frozen state. They are not fresh samples.

Table 1	Sample					
Frozen/thaw	Serum1	Plasma1	Serum2	Plasma2	Urine A	Urine B
Initial Condition	100.0%	100.0%	100.0%	100.0%	100.0%	100.0%
1st Time	99.2%	95.3%	93.0%	93.1%	93.6%	84.0%
2nd Time	91.3%	93.1%	91.4%	95.2%	88.9%	79.4%
3rd Time	92.5%	91.6%	92.4%	93.1%	71.2%	57.6%

37°C Acceleration test

Each sample was measured after incubation at 37 °C, and the ratio (%) of measured value against the initial condition is shown in Table 2. Initial condition means samples in the condition of “1 time*” of “Frozen/Thaw test” mention above. They are not fresh samples.

Table 2	Sample					
Incubation Time	Serum1	Plasma1	Serum2	Plasma2	Urine A	Urine B
Initial Condition	100.0%	100.0%	100.0%	100.0%	100.0%	100.0%
3 hours	106.0%	109.2%	108.2%	109.1%	66.7%	34.6%
6 hours	86.0%	101.1%	94.3%	104.2%	36.4%	13.8%
Overnight	70.2%	78.7%	57.3%	86.8%	8.6%	0.0%

Distributed by